

Francesco Iovine

PRSTD3.207

23/01/2017

### CUSTOMIZATION

### ASSEMBLED PRODUCT

Scale 2:1



Scale 1:1

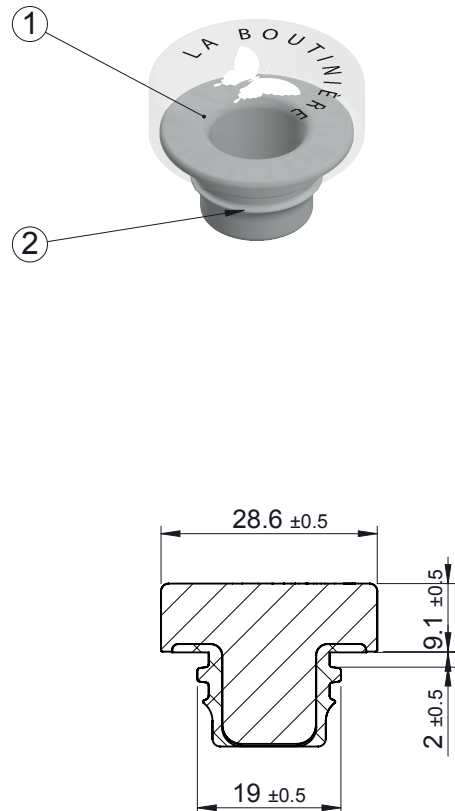

Nr	List of components	Material	Color	Customization
1	Plastic cap	PMMA	Transparent	2 Color White+Black Pad Printing
2	Synthetic insert	POE	Transparent	

\*All Tapi® Spa products are food contact certified and have been tested to ensure they are of the highest technological and quality standards. | Declaration of Conformity: All materials used by Tapi® for the product described in this Technical sheet is in conformity with all applicable EU regulations and directives and all FDA requirements. All new and updated certifications are available for viewing at Tapi® Spa Headquarters in Massanzago  
 WARNING: For non-food products such as cosmetics and/or fragrance oils, the Tapi® Technical Department will only guarantee performance after receiving the specific cosmetic or oil to be tested in the Tapi laboratories: a new special version of the product may be necessary for individual compatibility.